

S76/V76/P76 (OUTBOARD MOTOR)

STEEL SECURITY SHUTTER :: TECHNICAL DATASHEET



The S76 Steel security shutter provides low to medium security for commercial and industrial sites up to 64m². Also available as a punched (V76) or Perforated (P76) slat option, it is a common cost effective solution for many types of commercial and industrial application, including shopfronts, factories, warehouses, storage units and agricultural buildings. Also available with a tubular motor for smaller openings.



APPLICATIONS

Commercial sites requiring high security, for openings up to 64m². Internal or external face or reveal fit. Punched (V76) & Perforated (P76) slats can be incorporated as required for full or partial vision.

CURTAIN SLAT

Single skin 76mm curved steel standard galvanised finish. Profile Gauge of 18, 20 or 22, depending on the overall shutter opening.

Finish: Galvanised finish as standard. Plastisol and powder coating available on request (surcharge applies).

Slat Face:	76mm
Gauge Sizes:	22G, 20G, 18G
Weight per m ² :	9.8kg, 12.5kg, 16.7kg (solid profiles) 8.3kg, 10.6kg, 14.2kg (V & P profiles)
Maximum Width	7000mm (varies by operation & gauge)
Maximum Area:	42m ² (varies by operation & gauge)

Guide Height (mm)	Plate Size (mm)	
2695	305	tubular
4000	355	tubular
5000	400	tubular
6500	400	outboard
7000	450	outboard
8000	500	outboard

*These sizes apply to standard shutter roll methods only. Reverse rolled curtains will require larger casings than those shown. Plate sizes shown as a guide only and may increase dependent on shutter width.

Note: Outboard motors are generally larger than the plate.

CASING

Mild steel end plates as standard with optional casing and fascia available on request (surcharge applies).

Finish: Galvanised finish as standard. Option to powder coat any RAL / BS colour (surcharge applies).

BOTTOM RAIL

Galvanised steel 'L' or 'T' shaped bottom rail.

GUIDE CHANNELS

Galvanised steel guide channels. Width of 65mm or 100mm dependent on application. Windlocking guides and slat ends available.

Finish: Galvanised finish as standard. Option to powder coat any RAL / BS colour (surcharge applies).

OPERATION

Outboard Motor: GfA Safedrive & Ranger single or three phase motor with integrated safety brake, chain manual override and push button control station as standard. Other motors available on request, including Ellard, Link Controls and high speed options.

All motors have numerous control option variants such as remote and group or mobile phone activation.

Manual Spring & Lock: A counter-balanced spring and lock assembly is available for shutters up to 6.25m². A counter-balanced helical 'loaded shutter' controlled via hand chain is available for larger applications.

S76/V76/P76 (OUTBOARD MOTOR)

STEEL SECURITY SHUTTER :: TECHNICAL DATASHEET



MOTOR

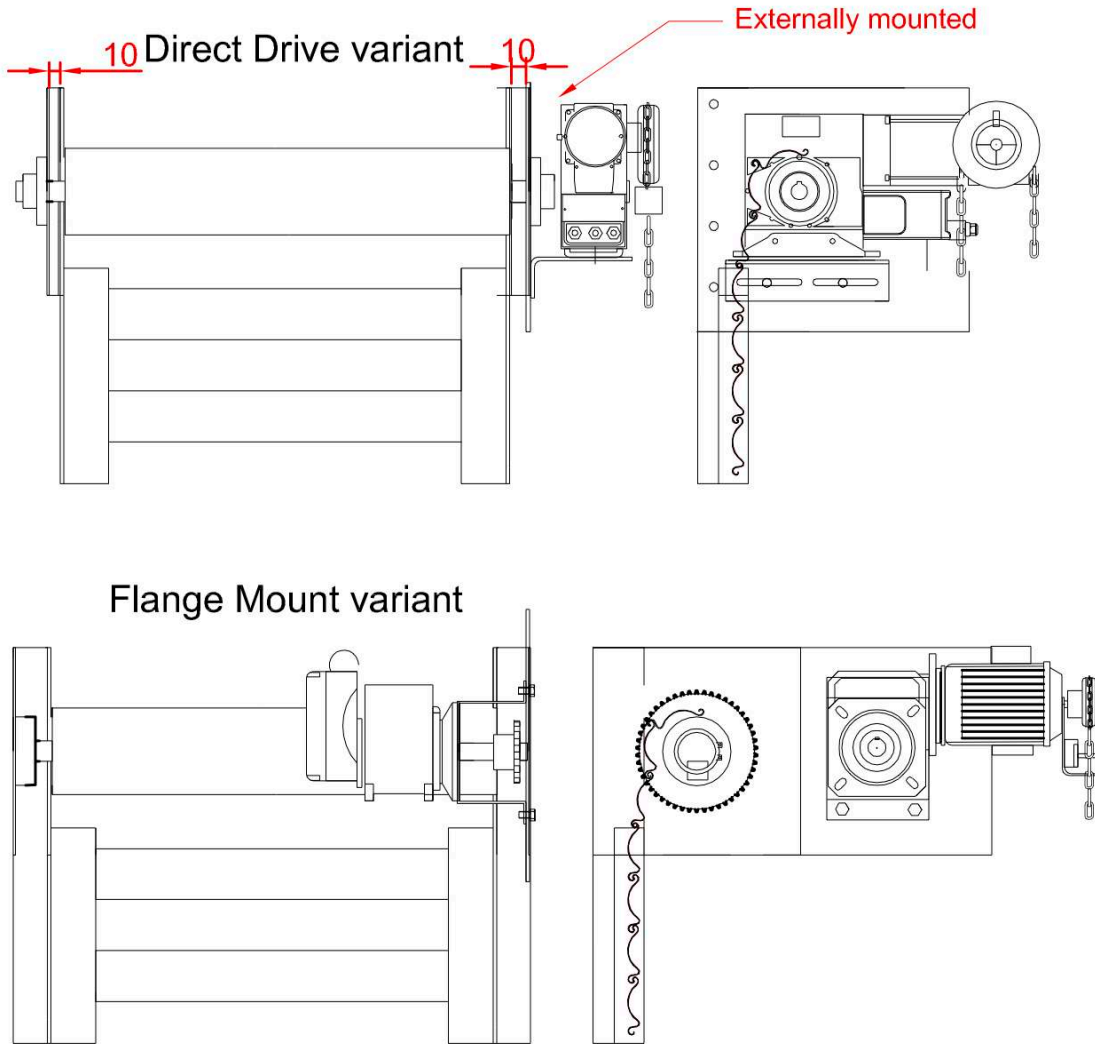

FIXING DETAIL

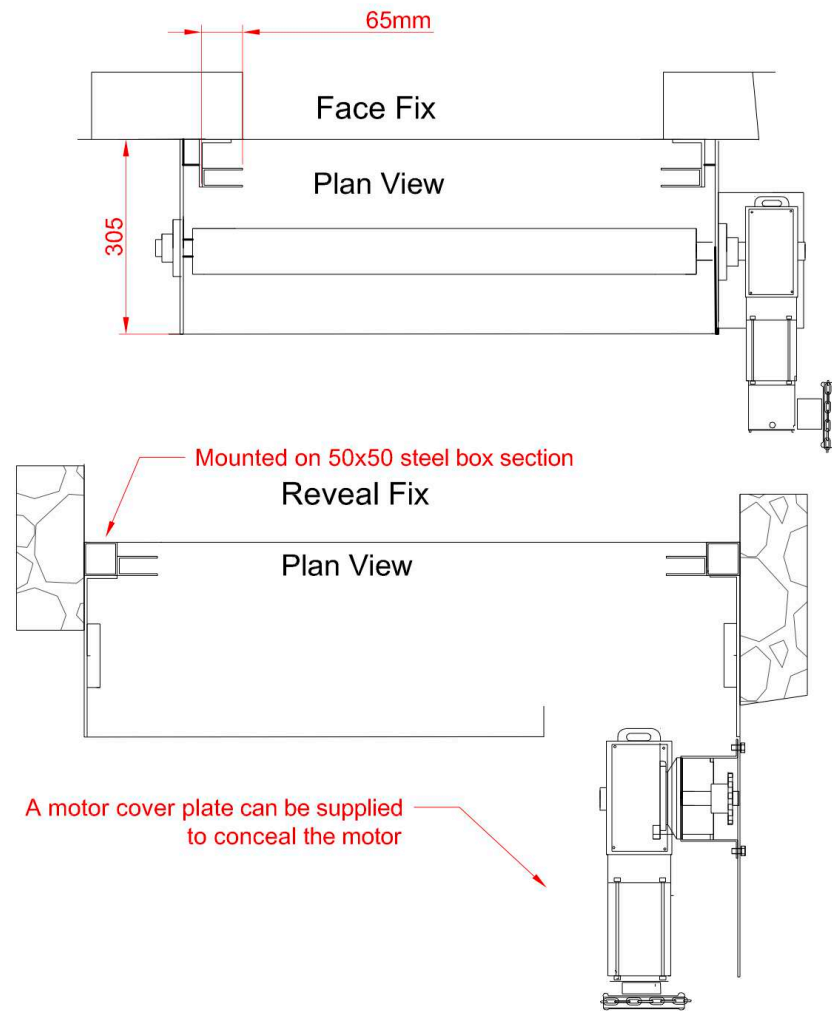

SLAT PROFILE

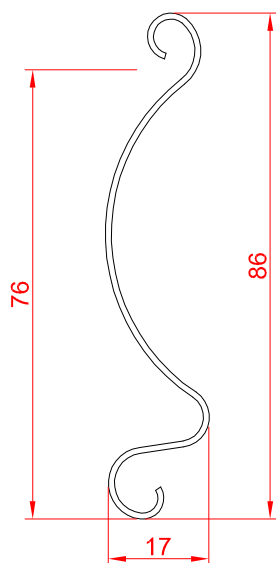

GUIDE CHANNELS

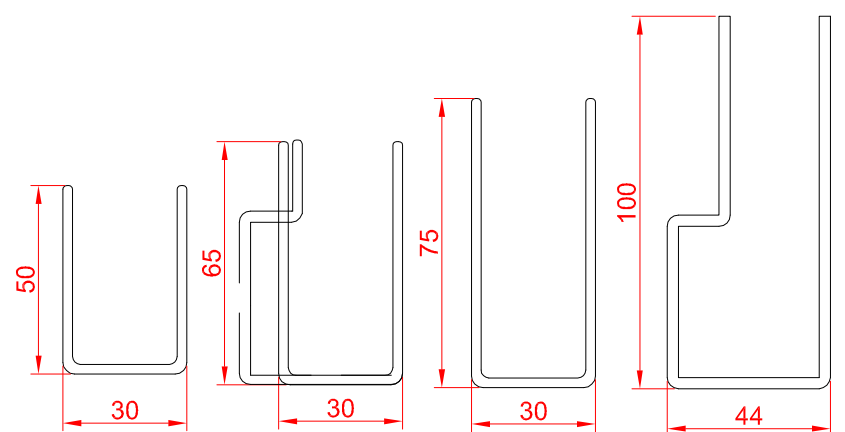

Manufactured by Aluroll

Unit 12 Artillery Business Park, Garrison Avenue, Park Hall, Oswestry, Shropshire, SY11 4AD :: Tel: 0800 977 8975 :: www.aluroll.co.uk

v0424